



CARBIDE DRILL SERIES

鎢鋼鑽頭系列



Index

目錄

鎢鋼鑽頭系列
CARBIDE DRILL SERIES



型號/頁碼 Type No. & Page	產品照片 Product Picture	鑄鐵 Cast Iron	碳鋼 Carbon Steels	合金鋼 工具鋼 Alloy Steels, Tool Steels	調質鋼 Prehardened Steels	不鏽鋼 Stainless Steels	鈦合金 Titanium Alloy	耐熱合金鋼 高溫合金鋼 & High Temp Alloy Steels	熱處理鋼 Hardened Steels ~55HRC	熱處理鋼 Hardened Steels 55HRC~
DAM P.252		★★★	★★★	★★★	★★★	★★★	★★★	★	★	★
DBM P.253		★★★	★★★	★★★	★★★	★★★	★★★	★	★	★
DAQ P.254		★★★	★★★	★★★	★★★	★★★	★★★	★	★	★
DBQ P.256		★★★	★★★	★★★	★★★	★★★	★★★	★	★	★
DAK P.258		★★★	★★★	★★★	★★★	★★★	★★★	★	★★	★
DBK P.260		★★★	★★★	★★★	★★★	★★★	★★★	★	★★	★
DAO P.262		★★★	★★★	★★★	★★★	★★★	★★★	★★	★★	★
DBO P.264		★★★	★★★	★★★	★★★	★★★	★★★	★★	★★	★
DCO P.266		★★★	★★★	★★★	★★★	★★★	★★★	★★	★★	★

鎢鋼鑽頭系列
CARBIDE DRILL SERIES



DAM

小徑鎢鋼鑽頭
CARBIDE MICRO DRILLS

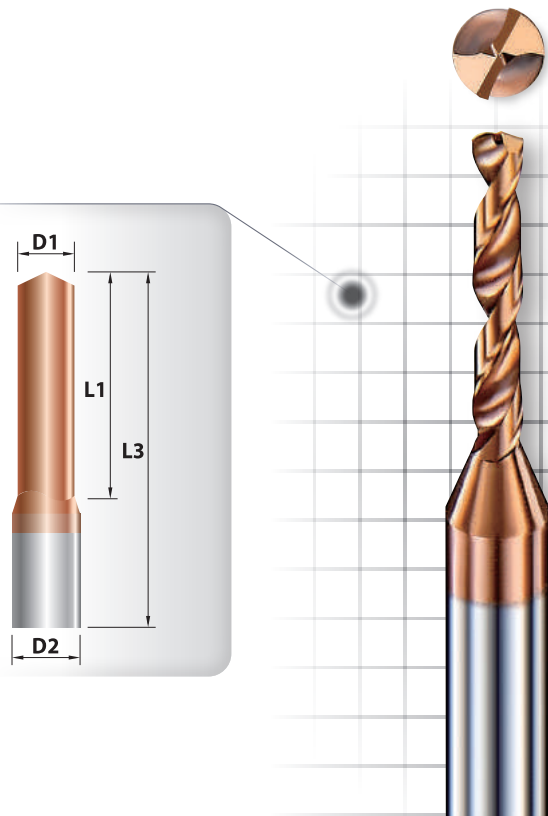

公差表 TOLERANCE unit: mm

直徑 D1	直徑公差值 D1 Tolerance	柄徑 D2	柄徑公差值 D2 Tolerance
0.5~3.0	0 -0.010	Ø3.0	0 -0.006

DBM

小徑鎢鋼鑽頭
CARBIDE MICRO DRILLS

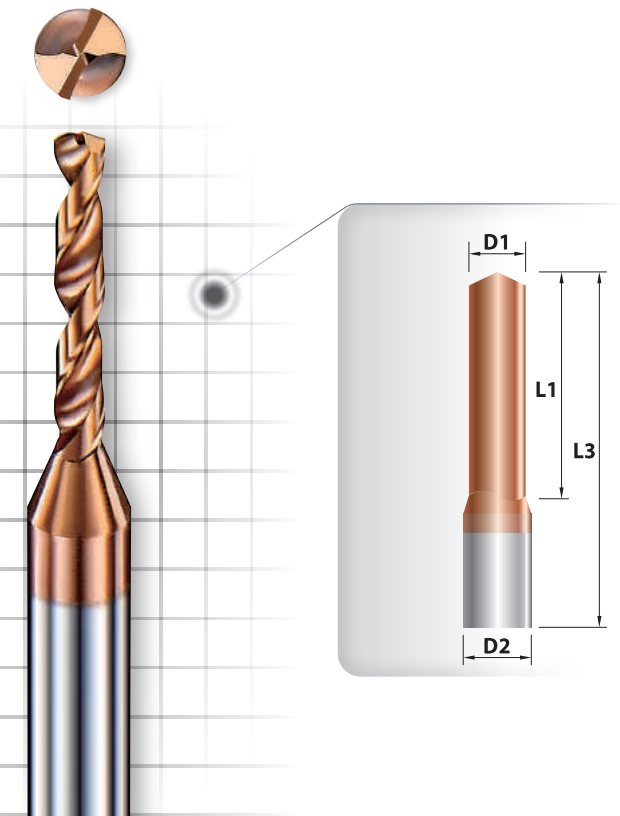

公差表 TOLERANCE unit: mm

直徑 D1	直徑公差值 D1 Tolerance	柄徑 D2	柄徑公差值 D2 Tolerance
0.5~3.0	0 -0.010	Ø3.0	0 -0.006

產品規格 SPECIFICATIONS

型號 Type No.	D1 直徑 Diameter	L1 刃長 Flute Length	L3 全長 O.A.L.	D2 柄徑 Shank Dia.
DAM005	0.5	4.6	38	3
DAM006	0.6	4.8	38	3
DAM007	0.7	5	38	3
DAM008	0.8	5.2	38	3
DAM009	0.9	5.4	38	3
DAM010	1.0	6	38	3
DAM011	1.1	12	50	3
DAM012	1.2	12	50	3
DAM013	1.3	12	50	3
DAM014	1.4	12	50	3
DAM015	1.5	12	50	3
DAM016	1.6	12	50	3
DAM017	1.7	12	50	3
DAM018	1.8	12	50	3
DAM019	1.9	12	50	3
DAM020	2.0	12	50	3
DAM021	2.1	18	60	3
DAM022	2.2	18	60	3
DAM023	2.3	18	60	3
DAM024	2.4	18	60	3

型號 Type No.	D1 直徑 Diameter	L1 刃長 Flute Length	L3 全長 O.A.L.	D2 柄徑 Shank Dia.
DAM025	2.5	18	60	3
DAM026	2.6	18	60	3
DAM027	2.7	18	60	3
DAM028	2.8	18	60	3
DAM029	2.9	18	60	3
DAM030	3.0	18	60	3

unit: mm

產品規格 SPECIFICATIONS

型號 Type No.	D1 直徑 Diameter	L1 刃長 Flute Length	L3 全長 O.A.L.	D2 柄徑 Shank Dia.
DBM005	0.5	10	50	3
DBM006	0.6	10	50	3
DBM007	0.7	10	50	3
DBM008	0.8	10	50	3
DBM009	0.9	10	50	3
DBM010	1.0	10	50	3
DBM011	1.1	20	50	3
DBM012	1.2	20	60	3
DBM013	1.3	20	60	3
DBM014	1.4	20	60	3
DBM015	1.5	20	60	3
DBM016	1.6	20	60	3
DBM017	1.7	20	60	3
DBM018	1.8	20	60	3
DBM019	1.9	20	60	3
DBM020	2.0	20	60	3
DBM021	2.1	28	66	3
DBM022	2.2	28	66	3
DBM023	2.3	28	66	3
DBM024	2.4	28	66	3

型號 Type No.	D1 直徑 Diameter	L1 刃長 Flute Length	L3 全長 O.A.L.	D2 柄徑 Shank Dia.
DBM025	2.5	28	66	3
DBM026	2.6	28	66	3
DBM027	2.7	28	66	3
DBM028	2.8	28	66	3
DBM029	2.9	28	66	3
DBM030	3.0	28	66	3

unit: mm

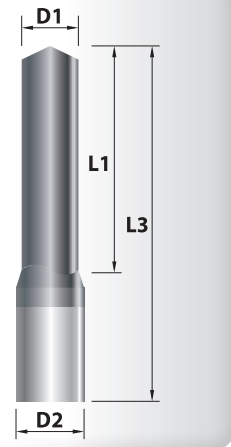

公差表 TOLERANCE unit : mm

直徑 D1	直徑公差值 D1 Tolerance	柄徑 D2	柄徑公差值 D2 Tolerance
3.0~5.9	0 -0.012	Ø4	0 -0.008
6.0~11.9	0 -0.015	Ø6	0 -0.008
12.0	0 -0.018	Ø8	0 -0.009
		Ø10	0 -0.009
		Ø12	0 -0.011

產品規格 SPECIFICATIONS

型號 Type No.	D1 直徑 Diameter	L1 刃長 Flute Length	L3 全長 O.A.L.	D2 柄徑 Shank Dia.
DAQ030	3.0	20	62	4
DAQ031	3.1	20	62	4
DAQ032	3.2	20	62	4
DAQ033	3.3	20	62	4
DAQ034	3.4	20	62	4
DAQ035	3.5	20	62	4
DAQ036	3.6	20	62	4
DAQ037	3.7	20	62	4
DAQ038	3.8	24	66	4
DAQ039	3.9	24	66	4
DAQ040	4.0	24	66	4
DAQ041	4.1	24	66	6
DAQ042	4.2	24	66	6
DAQ043	4.3	24	66	6
DAQ044	4.4	24	66	6
DAQ045	4.5	24	66	6
DAQ046	4.6	24	66	6
DAQ047	4.7	24	66	6
DAQ048	4.8	28	66	6
DAQ049	4.9	28	66	6
DAQ050	5.0	28	66	6

型號 Type No.	D1 直徑 Diameter	L1 刃長 Flute Length	L3 全長 O.A.L.	D2 柄徑 Shank Dia.
DAQ051	5.1	28	66	6
DAQ052	5.2	28	66	6
DAQ053	5.3	28	66	6
DAQ054	5.4	28	66	6
DAQ055	5.5	28	66	6
DAQ056	5.6	28	66	6
DAQ057	5.7	28	66	6
DAQ058	5.8	28	66	6
DAQ059	5.9	28	66	6
DAQ060	6.0	28	66	6
DAQ061	6.1	34	79	8
DAQ062	6.2	34	79	8
DAQ063	6.3	34	79	8
DAQ064	6.4	34	79	8
DAQ065	6.5	34	79	8
DAQ066	6.6	34	79	8
DAQ067	6.7	34	79	8
DAQ068	6.8	34	79	8
DAQ069	6.9	34	79	8
DAQ070	7.0	34	79	8
DAQ071	7.1	41	79	8

型號 Type No.	D1 直徑 Diameter	L1 刃長 Flute Length	L3 全長 O.A.L.	D2 柄徑 Shank Dia.
DAQ072	7.2	41	79	8
DAQ073	7.3	41	79	8
DAQ074	7.4	41	79	8
DAQ075	7.5	41	79	8
DAQ076	7.6	41	79	8
DAQ077	7.7	41	79	8
DAQ078	7.8	41	79	8
DAQ079	7.9	41	79	8
DAQ080	8.0	41	79	8
DAQ081	8.1	47	89	10
DAQ082	8.2	47	89	10
DAQ083	8.3	47	89	10
DAQ084	8.4	47	89	10
DAQ085	8.5	47	89	10
DAQ086	8.6	47	89	10
DAQ087	8.7	47	89	10
DAQ088	8.8	47	89	10
DAQ089	8.9	47	89	10
DAQ090	9.0	47	89	10
DAQ091	9.1	47	89	10
DAQ092	9.2	47	89	10
DAQ093	9.3	47	89	10
DAQ094	9.4	47	89	10
DAQ095	9.5	47	89	10
DAQ096	9.6	47	89	10
DAQ097	9.7	47	89	10
DAQ098	9.8	47	89	10
DAQ099	9.9	47	89	10
DAQ100	10.0	47	89	10
DAQ101	10.1	55	102	12
DAQ102	10.2	55	102	12
DAQ103	10.3	55	102	12
DAQ104	10.4	55	102	12
DAQ105	10.5	55	102	12
DAQ106	10.6	55	102	12
DAQ107	10.7	55	102	12
DAQ108	10.8	55	102	12
DAQ109	10.9	55	102	12
DAQ110	11.0	55	102	12
DAQ111	11.1	55	102	12
DAQ112	11.2	55	102	12
DAQ113	11.3	55	102	12
DAQ114	11.4	55	102	12
DAQ115	11.5	55	102	12
DAQ116	11.6	55	102	12
DAQ117	11.7	55	102	12
DAQ118	11.8	55	102	12
DAQ119	11.9	55	102	12
DAQ120	12.0	55	102	12

unit : mm

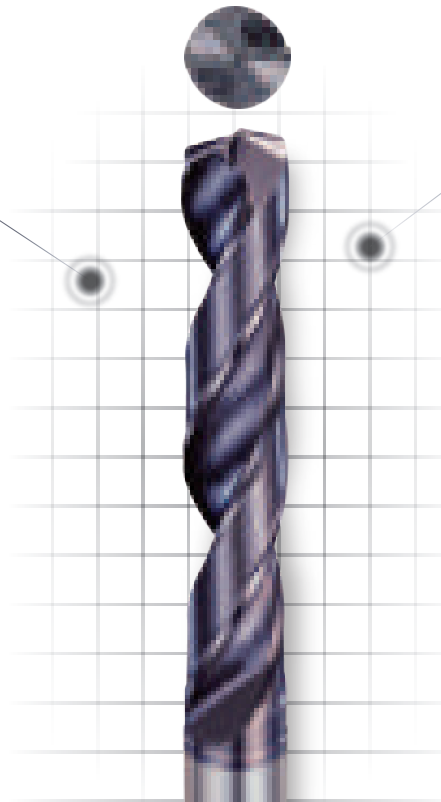
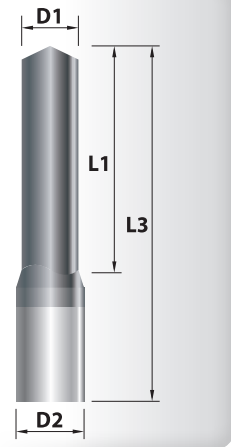

公差表 TOLERANCE unit : mm

直徑 D1	直徑公差值 D1 Tolerance	柄徑 D2	柄徑公差值 D2 Tolerance
3.0~5.9	0 -0.012	Ø6	0 -0.008
6.0~11.9	0 -0.015	Ø8	0 -0.009
12.0	0 -0.018	Ø10	0 -0.009
		Ø12	0 -0.011

產品規格 SPECIFICATIONS

型號 Type No.	D1 直徑 Diameter	L1 刃長 Flute Length	L3 全長 O.A.L.	D2 柄徑 Shank Dia.
DBQ030	3.0	28	66	6
DBQ031	3.1	28	66	6
DBQ032	3.2	28	66	6
DBQ033	3.3	28	66	6
DBQ034	3.4	28	66	6
DBQ035	3.5	28	66	6
DBQ036	3.6	28	66	6
DBQ037	3.7	28	66	6
DBQ038	3.8	36	74	6
DBQ039	3.9	36	74	6
DBQ040	4.0	36	74	6
DBQ041	4.1	36	74	6
DBQ042	4.2	36	74	6
DBQ043	4.3	36	74	6
DBQ044	4.4	36	74	6
DBQ045	4.5	36	74	6
DBQ046	4.6	36	74	6
DBQ047	4.7	36	74	6
DBQ048	4.8	44	82	6
DBQ049	4.9	44	82	6
DBQ050	5.0	44	82	6

型號 Type No.	D1 直徑 Diameter	L1 刃長 Flute Length	L3 全長 O.A.L.	D2 柄徑 Shank Dia.
DBQ051	5.1	44	82	6
DBQ052	5.2	44	82	6
DBQ053	5.3	44	82	6
DBQ054	5.4	44	82	6
DBQ055	5.5	44	82	6
DBQ056	5.6	44	82	6
DBQ057	5.7	44	82	6
DBQ058	5.8	44	82	6
DBQ059	5.9	44	82	6
DBQ060	6.0	44	82	6
DBQ061	6.1	53	91	8
DBQ062	6.2	53	91	8
DBQ063	6.3	53	91	8
DBQ064	6.4	53	91	8
DBQ065	6.5	53	91	8
DBQ066	6.6	53	91	8
DBQ067	6.7	53	91	8
DBQ068	6.8	53	91	8
DBQ069	6.9	53	91	8
DBQ070	7.0	53	91	8
DBQ071	7.1	53	91	8

型號 Type No.	D1 直徑 Diameter	L1 刃長 Flute Length	L3 全長 O.A.L.	D2 柄徑 Shank Dia.
DBQ072	7.2	53	91	8
DBQ073	7.3	53	91	8
DBQ074	7.4	53	91	8
DBQ075	7.5	53	91	8
DBQ076	7.6	53	91	8
DBQ077	7.7	53	91	8
DBQ078	7.8	53	91	8
DBQ079	7.9	53	91	8
DBQ080	8.0	53	91	8
DBQ081	8.1	61	103	10
DBQ082	8.2	61	103	10
DBQ083	8.3	61	103	10
DBQ084	8.4	61	103	10
DBQ085	8.5	61	103	10
DBQ086	8.6	61	103	10
DBQ087	8.7	61	103	10
DBQ088	8.8	61	103	10
DBQ089	8.9	61	103	10
DBQ090	9.0	61	103	10
DBQ091	9.1	61	103	10
DBQ092	9.2	61	103	10
DBQ093	9.3	61	103	10
DBQ094	9.4	61	103	10
DBQ095	9.5	61	103	10
DBQ096	9.6	61	103	10
DBQ097	9.7	61	103	10
DBQ098	9.8	61	103	10
DBQ099	9.9	61	103	10
DBQ100	10.0	61	103	10
DBQ101	10.1	71	118	12
DBQ102	10.2	71	118	12
DBQ103	10.3	71	118	12
DBQ104	10.4	71	118	12
DBQ105	10.5	71	118	12
DBQ106	10.6	71	118	12
DBQ107	10.7	71	118	12
DBQ108	10.8	71	118	12
DBQ109	10.9	71	118	12
DBQ110	11.0	71	118	12
DBQ111	11.1	71	118	12
DBQ112	11.2	71	118	12
DBQ113	11.3	71	118	12
DBQ114	11.4	71	118	12
DBQ115	11.5	71	118	12
DBQ116	11.6	71	118	12
DBQ117	11.7	71	118	12
DBQ118	11.8	71	118	12
DBQ119	11.9	71	118	12
DBQ120	12.0	71	118	12



DAK

鎢鋼鑽頭
CARBIDE DRILLS

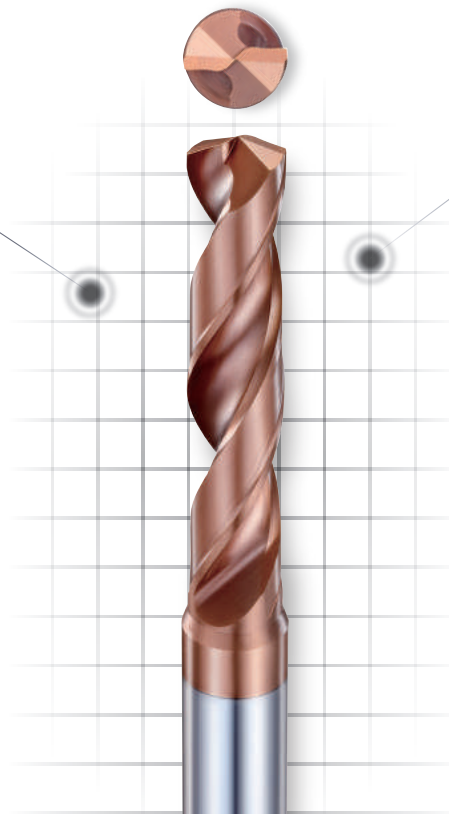
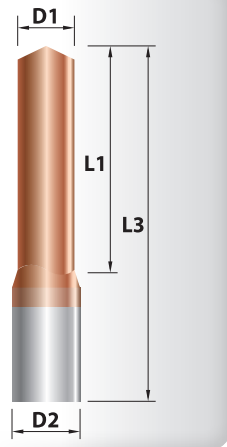

公差表 TOLERANCE unit : mm

直徑 D1	直徑公差值 D1 Tolerance	柄徑 D2	柄徑公差值 D2 Tolerance
3.0~5.9	-0.012	Ø6	-0.008
6.0~11.9	-0.015	Ø8	-0.009
12.0~15.8	-0.018	Ø10	-0.009
16.0~20.0	-0.021	Ø12	-0.011
		Ø14	-0.011
		Ø16	-0.011
		Ø18	-0.011
		Ø20	-0.013

產品規格 SPECIFICATIONS

型號 Type No.	D1 直徑 Diameter	L1 刃長 Flute Length	L3 全長 O.A.L.	D2 柄徑 Shank Dia.	型號 Type No.	D1 直徑 Diameter	L1 刃長 Flute Length	L3 全長 O.A.L.	D2 柄徑 Shank Dia.
DAK030	3.0	20	62	6	DAK051	5.1	28	66	6
DAK031	3.1	20	62	6	DAK052	5.2	28	66	6
DAK032	3.2	20	62	6	DAK053	5.3	28	66	6
DAK033	3.3	20	62	6	DAK054	5.4	28	66	6
DAK034	3.4	20	62	6	DAK055	5.5	28	66	6
DAK035	3.5	20	62	6	DAK056	5.6	28	66	6
DAK036	3.6	20	62	6	DAK057	5.7	28	66	6
DAK037	3.7	20	62	6	DAK058	5.8	28	66	6
DAK038	3.8	24	66	6	DAK059	5.9	28	66	6
DAK039	3.9	24	66	6	DAK060	6.0	28	66	6
DAK040	4.0	24	66	6	DAK061	6.1	34	79	8
DAK041	4.1	24	66	6	DAK062	6.2	34	79	8
DAK042	4.2	24	66	6	DAK063	6.3	34	79	8
DAK043	4.3	24	66	6	DAK064	6.4	34	79	8
DAK044	4.4	24	66	6	DAK065	6.5	34	79	8
DAK045	4.5	24	66	6	DAK066	6.6	34	79	8
DAK046	4.6	24	66	6	DAK067	6.7	34	79	8
DAK047	4.7	24	66	6	DAK068	6.8	34	79	8
DAK048	4.8	28	66	6	DAK069	6.9	34	79	8
DAK049	4.9	28	66	6	DAK070	7.0	34	79	8
DAK050	5.0	28	66	6	DAK071	7.1	41	79	8

型號 Type No.	D1 直徑 Diameter	L1 刃長 Flute Length	L3 全長 O.A.L.	D2 柄徑 Shank Dia.
DAK072	7.2	41	79	8
DAK073	7.3	41	79	8
DAK074	7.4	41	79	8
DAK075	7.5	41	79	8
DAK076	7.6	41	79	8
DAK077	7.7	41	79	8
DAK078	7.8	41	79	8
DAK079	7.9	41	79	8
DAK080	8.0	41	79	8
DAK081	8.1	47	89	10
DAK082	8.2	47	89	10
DAK083	8.3	47	89	10
DAK084	8.4	47	89	10
DAK085	8.5	47	89	10
DAK086	8.6	47	89	10
DAK087	8.7	47	89	10
DAK088	8.8	47	89	10
DAK089	8.9	47	89	10
DAK090	9.0	47	89	10
DAK091	9.1	47	89	10
DAK092	9.2	47	89	10
DAK093	9.3	47	89	10
DAK094	9.4	47	89	10
DAK095	9.5	47	89	10
DAK096	9.6	47	89	10
DAK097	9.7	47	89	10
DAK098	9.8	47	89	10
DAK099	9.9	47	89	10
DAK100	10.0	47	89	10
DAK101	10.1	55	102	12
DAK102	10.2	55	102	12
DAK103	10.3	55	102	12
DAK104	10.4	55	102	12
DAK105	10.5	55	102	12
DAK106	10.6	55	102	12
DAK107	10.7	55	102	12
DAK108	10.8	55	102	12
DAK109	10.9	55	102	12
DAK110	11.0	55	102	12
DAK111	11.1	55	102	12
DAK112	11.2	55	102	12
DAK113	11.3	55	102	12
DAK114	11.4	55	102	12
DAK115	11.5	55	102	12
DAK116	11.6	55	102	12
DAK117	11.7	55	102	12
DAK118	11.8	55	102	12
DAK119	11.9	55	102	12
DAK120	12.0	55	102	12
DAK123	12.3	60	107	14
DAK125	12.5	60	107	14

型號 Type No.	D1 直徑 Diameter	L1 刃長 Flute Length	L3 全長 O.A.L.	D2 柄徑 Shank Dia.
DAK128	12.8	60	107	14
DAK130	13.0	60	107	14
DAK135	13.5	60	107	14
DAK138	13.8	60	107	14
DAK140	14.0	60	107	14
DAK145	14.5	65	115	16
DAK148	14.8	65	115	16
DAK150	15.0	65	115	16
DAK155	15.5	65	115	16
DAK158	15.8	65	115	16
DAK160	16.0	65	115	16
DAK165	16.5	73	123	18
DAK168	16.8	73	123	18
DAK170	17.0	73	123	18
DAK175	17.5	73	123	18
DAK178	17.8	73	123	18
DAK180	18.0	73	123	18
DAK185	18.5	79	131	20
DAK190	19.0	79	131	20
DAK195	19.5	79	131	20
DAK198	19.8	79	131	20
DAK200	20.0	79	131	20

unit : mm

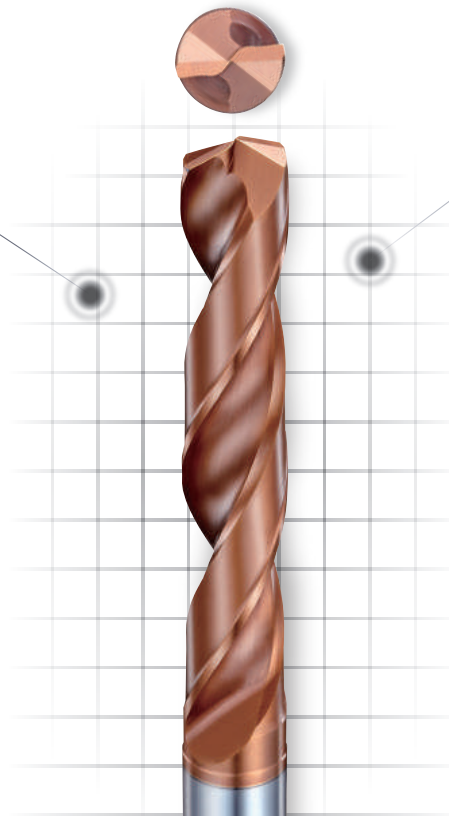
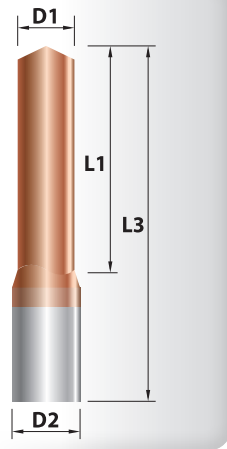

公差表 TOLERANCE unit : mm

直徑 D1	直徑公差值 D1 Tolerance	柄徑 D2	柄徑公差值 D2 Tolerance
3.0~5.9	-0.012	Ø6	-0.008
6.0~11.9	-0.015	Ø8	-0.009
12.0~15.8	-0.018	Ø10	-0.009
16.0~20.0	-0.021	Ø12	-0.011
		Ø14	-0.011
		Ø16	-0.011
		Ø18	-0.011
		Ø20	-0.013

產品規格 SPECIFICATIONS

型號 Type No.	D1 直徑 Diameter	L1 刃長 Flute Length	L3 全長 O.A.L.	D2 柄徑 Shank Dia.	型號 Type No.	D1 直徑 Diameter	L1 刃長 Flute Length	L3 全長 O.A.L.	D2 柄徑 Shank Dia.
DBK030	3.0	28	66	6	DBK051	5.1	44	82	6
DBK031	3.1	28	66	6	DBK052	5.2	44	82	6
DBK032	3.2	28	66	6	DBK053	5.3	44	82	6
DBK033	3.3	28	66	6	DBK054	5.4	44	82	6
DBK034	3.4	28	66	6	DBK055	5.5	44	82	6
DBK035	3.5	28	66	6	DBK056	5.6	44	82	6
DBK036	3.6	28	66	6	DBK057	5.7	44	82	6
DBK037	3.7	28	66	6	DBK058	5.8	44	82	6
DBK038	3.8	36	74	6	DBK059	5.9	44	82	6
DBK039	3.9	36	74	6	DBK060	6.0	44	82	6
DBK040	4.0	36	74	6	DBK061	6.1	53	91	8
DBK041	4.1	36	74	6	DBK062	6.2	53	91	8
DBK042	4.2	36	74	6	DBK063	6.3	53	91	8
DBK043	4.3	36	74	6	DBK064	6.4	53	91	8
DBK044	4.4	36	74	6	DBK065	6.5	53	91	8
DBK045	4.5	36	74	6	DBK066	6.6	53	91	8
DBK046	4.6	36	74	6	DBK067	6.7	53	91	8
DBK047	4.7	36	74	6	DBK068	6.8	53	91	8
DBK048	4.8	44	82	6	DBK069	6.9	53	91	8
DBK049	4.9	44	82	6	DBK070	7.0	53	91	8
DBK050	5.0	44	82	6	DBK071	7.1	53	91	8

型號 Type No.	D1 直徑 Diameter	L1 刃長 Flute Length	L3 全長 O.A.L.	D2 柄徑 Shank Dia.
DBK072	7.2	53	91	8
DBK073	7.3	53	91	8
DBK074	7.4	53	91	8
DBK075	7.5	53	91	8
DBK076	7.6	53	91	8
DBK077	7.7	53	91	8
DBK078	7.8	53	91	8
DBK079	7.9	53	91	8
DBK080	8.0	53	91	8
DBK081	8.1	61	103	10
DBK082	8.2	61	103	10
DBK083	8.3	61	103	10
DBK084	8.4	61	103	10
DBK085	8.5	61	103	10
DBK086	8.6	61	103	10
DBK087	8.7	61	103	10
DBK088	8.8	61	103	10
DBK089	8.9	61	103	10
DBK090	9.0	61	103	10
DBK091	9.1	61	103	10
DBK092	9.2	61	103	10
DBK093	9.3	61	103	10
DBK094	9.4	61	103	10
DBK095	9.5	61	103	10
DBK096	9.6	61	103	10
DBK097	9.7	61	103	10
DBK098	9.8	61	103	10
DBK099	9.9	61	103	10
DBK100	10.0	61	103	10
DBK101	10.1	71	118	12
DBK102	10.2	71	118	12
DBK103	10.3	71	118	12
DBK104	10.4	71	118	12
DBK105	10.5	71	118	12
DBK106	10.6	71	118	12
DBK107	10.7	71	118	12
DBK108	10.8	71	118	12
DBK109	10.9	71	118	12
DBK110	11.0	71	118	12
DBK111	11.1	71	118	12
DBK112	11.2	71	118	12
DBK113	11.3	71	118	12
DBK114	11.4	71	118	12
DBK115	11.5	71	118	12
DBK116	11.6	71	118	12
DBK117	11.7	71	118	12
DBK118	11.8	71	118	12
DBK119	11.9	71	118	12
DBK120	12.0	71	118	12
DBK123	12.3	77	124	14
DBK125	12.5	77	124	14

型號 Type No.	D1 直徑 Diameter	L1 刃長 Flute Length	L3 全長 O.A.L.	D2 柄徑 Shank Dia.
DBK128	12.8	77	124	14
DBK130	13.0	77	124	14
DBK135	13.5	77	124	14
DBK138	13.8	77	124	14
DBK140	14.0	77	124	14
DBK145	14.5	83	133	16
DBK148	14.8	83	133	16
DBK150	15.0	83	133	16
DBK155	15.5	83	133	16
DBK158	15.8	83	133	16
DBK160	16.0	83	133	16
DBK165	16.5	93	143	18
DBK168	16.8	93	143	18
DBK170	17.0	93	143	18
DBK175	17.5	93	143	18
DBK178	17.8	93	143	18
DBK180	18.0	93	143	18
DBK185	18.5	101	153	20
DBK190	19.0	101	153	20
DBK195	19.5	101	153	20
DBK198	19.8	101	153	20
DBK200	20.0	101	153	20

unit : mm

DAO

鎢鋼鑽頭(內冷孔)
CARBIDE DRILLS W/ INTERNAL COOLANT HOLE

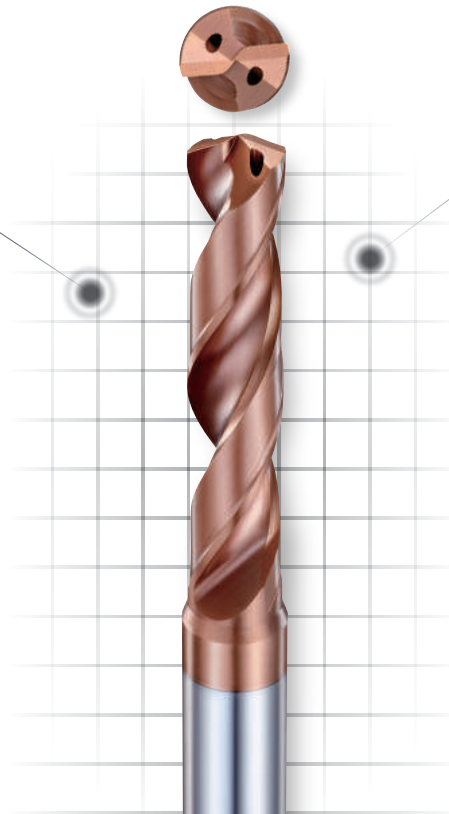
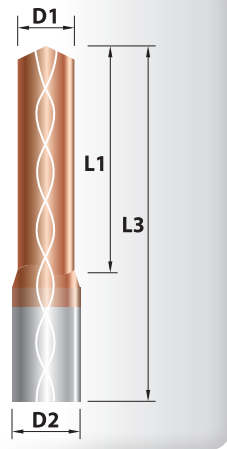

公差表 TOLERANCE unit : mm

直徑 D1	直徑公差值 D1 Tolerance	柄徑 D2	柄徑公差值 D2 Tolerance
3.0~5.9	-0.012	Ø6	-0.008
6.0~11.9	-0.015	Ø8	-0.009
12.0~15.8	-0.018	Ø10	-0.009
16.0~20.0	-0.021	Ø12	-0.011
		Ø14	-0.011
		Ø16	-0.011
		Ø18	-0.011
		Ø20	-0.013

產品規格 SPECIFICATIONS

型號 Type No.	D1 直徑 Diameter	L1 刃長 Flute Length	L3 全長 O.A.L.	D2 柄徑 Shank Dia.	型號 Type No.	D1 直徑 Diameter	L1 刃長 Flute Length	L3 全長 O.A.L.	D2 柄徑 Shank Dia.
DAO030	3.0	20	62	6	DAO051	5.1	28	66	6
DAO031	3.1	20	62	6	DAO052	5.2	28	66	6
DAO032	3.2	20	62	6	DAO053	5.3	28	66	6
DAO033	3.3	20	62	6	DAO054	5.4	28	66	6
DAO034	3.4	20	62	6	DAO055	5.5	28	66	6
DAO035	3.5	20	62	6	DAO056	5.6	28	66	6
DAO036	3.6	20	62	6	DAO057	5.7	28	66	6
DAO037	3.7	20	62	6	DAO058	5.8	28	66	6
DAO038	3.8	24	66	6	DAO059	5.9	28	66	6
DAO039	3.9	24	66	6	DAO060	6.0	28	66	6
DAO040	4.0	24	66	6	DAO061	6.1	34	79	8
DAO041	4.1	24	66	6	DAO062	6.2	34	79	8
DAO042	4.2	24	66	6	DAO063	6.3	34	79	8
DAO043	4.3	24	66	6	DAO064	6.4	34	79	8
DAO044	4.4	24	66	6	DAO065	6.5	34	79	8
DAO045	4.5	24	66	6	DAO066	6.6	34	79	8
DAO046	4.6	24	66	6	DAO067	6.7	34	79	8
DAO047	4.7	24	66	6	DAO068	6.8	34	79	8
DAO048	4.8	28	66	6	DAO069	6.9	34	79	8
DAO049	4.9	28	66	6	DAO070	7.0	34	79	8
DAO050	5.0	28	66	6	DAO071	7.1	41	79	8

型號 Type No.	D1 直徑 Diameter	L1 刃長 Flute Length	L3 全長 O.A.L.	D2 柄徑 Shank Dia.
DAO072	7.2	41	79	8
DAO073	7.3	41	79	8
DAO074	7.4	41	79	8
DAO075	7.5	41	79	8
DAO076	7.6	41	79	8
DAO077	7.7	41	79	8
DAO078	7.8	41	79	8
DAO079	7.9	41	79	8
DAO080	8.0	41	79	8
DAO081	8.1	47	89	10
DAO082	8.2	47	89	10
DAO083	8.3	47	89	10
DAO084	8.4	47	89	10
DAO085	8.5	47	89	10
DAO086	8.6	47	89	10
DAO087	8.7	47	89	10
DAO088	8.8	47	89	10
DAO089	8.9	47	89	10
DAO090	9.0	47	89	10
DAO091	9.1	47	89	10
DAO092	9.2	47	89	10
DAO093	9.3	47	89	10
DAO094	9.4	47	89	10
DAO095	9.5	47	89	10
DAO096	9.6	47	89	10
DAO097	9.7	47	89	10
DAO098	9.8	47	89	10
DAO099	9.9	47	89	10
DAO100	10.0	47	89	10
DAO101	10.1	55	102	12
DAO102	10.2	55	102	12
DAO103	10.3	55	102	12
DAO104	10.4	55	102	12
DAO105	10.5	55	102	12
DAO106	10.6	55	102	12
DAO107	10.7	55	102	12
DAO108	10.8	55	102	12
DAO109	10.9	55	102	12
DAO110	11.0	55	102	12
DAO111	11.1	55	102	12
DAO112	11.2	55	102	12
DAO113	11.3	55	102	12
DAO114	11.4	55	102	12
DAO115	11.5	55	102	12
DAO116	11.6	55	102	12
DAO117	11.7	55	102	12
DAO118	11.8	55	102	12
DAO119	11.9	55	102	12
DAO120	12.0	55	102	12
DAO125	12.5	60	107	14
DAO130	13.0	60	107	14

型號 Type No.	D1 直徑 Diameter	L1 刃長 Flute Length	L3 全長 O.A.L.	D2 柄徑 Shank Dia.
DAO135	13.5	60	107	14
DAO140	14.0	60	107	14
DAO145	14.5	65	115	16
DAO150	15.0	65	115	16
DAO155	15.5	65	115	16
DAO160	16.0	65	115	16
DAO165	16.5	73	123	18
DAO170	17.0	73	123	18
DAO175	17.5	73	123	18
DAO180	18.0	73	123	18
DAO185	18.5	79	131	20
DAO190	19.0	79	131	20
DAO195	19.5	79	131	20
DAO200	20.0	79	131	20

unit : mm

DBO

鎢鋼鑽頭(內冷孔)
CARBIDE DRILLS W/ INTERNAL COOLANT HOLE

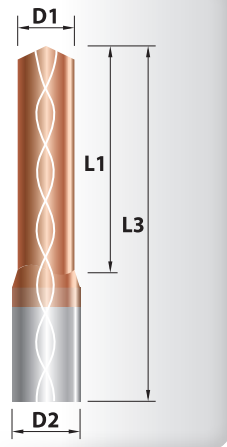

公差表 TOLERANCE unit : mm

直徑 D1	直徑公差值 D1 Tolerance	柄徑 D2	柄徑公差值 D2 Tolerance
3.0~5.9	-0.012	Ø6	-0.008
6.0~11.9	-0.015	Ø8	-0.009
12.0~15.8	-0.018	Ø10	-0.009
16.0~20.0	-0.021	Ø12	-0.011
		Ø14	-0.011
		Ø16	-0.011
		Ø18	-0.011
		Ø20	-0.013

產品規格 SPECIFICATIONS

型號 Type No.	D1 直徑 Diameter	L1 刃長 Flute Length	L3 全長 O.A.L.	D2 柄徑 Shank Dia.	型號 Type No.	D1 直徑 Diameter	L1 刃長 Flute Length	L3 全長 O.A.L.	D2 柄徑 Shank Dia.
DBO030	3.0	28	66	6	DBO051	5.1	44	82	6
DBO031	3.1	28	66	6	DBO052	5.2	44	82	6
DBO032	3.2	28	66	6	DBO053	5.3	44	82	6
DBO033	3.3	28	66	6	DBO054	5.4	44	82	6
DBO034	3.4	28	66	6	DBO055	5.5	44	82	6
DBO035	3.5	28	66	6	DBO056	5.6	44	82	6
DBO036	3.6	28	66	6	DBO057	5.7	44	82	6
DBO037	3.7	28	66	6	DBO058	5.8	44	82	6
DBO038	3.8	36	74	6	DBO059	5.9	44	82	6
DBO039	3.9	36	74	6	DBO060	6.0	44	82	6
DBO040	4.0	36	74	6	DBO061	6.1	53	91	8
DBO041	4.1	36	74	6	DBO062	6.2	53	91	8
DBO042	4.2	36	74	6	DBO063	6.3	53	91	8
DBO043	4.3	36	74	6	DBO064	6.4	53	91	8
DBO044	4.4	36	74	6	DBO065	6.5	53	91	8
DBO045	4.5	36	74	6	DBO066	6.6	53	91	8
DBO046	4.6	36	74	6	DBO067	6.7	53	91	8
DBO047	4.7	36	74	6	DBO068	6.8	53	91	8
DBO048	4.8	44	82	6	DBO069	6.9	53	91	8
DBO049	4.9	44	82	6	DBO070	7.0	53	91	8
DBO050	5.0	44	82	6	DBO071	7.1	53	91	8

型號 Type No.	D1 直徑 Diameter	L1 刃長 Flute Length	L3 全長 O.A.L.	D2 柄徑 Shank Dia.
DBO072	7.2	53	91	8
DBO073	7.3	53	91	8
DBO074	7.4	53	91	8
DBO075	7.5	53	91	8
DBO076	7.6	53	91	8
DBO077	7.7	53	91	8
DBO078	7.8	53	91	8
DBO079	7.9	53	91	8
DBO080	8.0	53	91	8
DBO081	8.1	61	103	10
DBO082	8.2	61	103	10
DBO083	8.3	61	103	10
DBO084	8.4	61	103	10
DBO085	8.5	61	103	10
DBO086	8.6	61	103	10
DBO087	8.7	61	103	10
DBO088	8.8	61	103	10
DBO089	8.9	61	103	10
DBO090	9.0	61	103	10
DBO091	9.1	61	103	10
DBO092	9.2	61	103	10
DBO093	9.3	61	103	10
DBO094	9.4	61	103	10
DBO095	9.5	61	103	10
DBO096	9.6	61	103	10
DBO097	9.7	61	103	10
DBO098	9.8	61	103	10
DBO099	9.9	61	103	10
DBO100	10.0	61	103	10
DBO101	10.1	71	118	12
DBO102	10.2	71	118	12
DBO103	10.3	71	118	12
DBO104	10.4	71	118	12
DBO105	10.5	71	118	12
DBO106	10.6	71	118	12
DBO107	10.7	71	118	12
DBO108	10.8	71	118	12
DBO109	10.9	71	118	12
DBO110	11.0	71	118	12
DBO111	11.1	71	118	12
DBO112	11.2	71	118	12
DBO113	11.3	71	118	12
DBO114	11.4	71	118	12
DBO115	11.5	71	118	12
DBO116	11.6	71	118	12
DBO117	11.7	71	118	12
DBO118	11.8	71	118	12
DBO119	11.9	71	118	12
DBO120	12.0	71	118	12
DBO125	12.5	77	124	14
DBO130	13.0	77	124	14

型號 Type No.	D1 直徑 Diameter	L1 刃長 Flute Length	L3 全長 O.A.L.	D2 柄徑 Shank Dia.
DBO135	13.5	77	124	14
DBO140	14.0	77	124	14
DBO145	14.5	83	133	16
DBO150	15.0	83	133	16
DBO155	15.5	83	133	16
DBO160	16.0	83	133	16
DBO165	16.5	93	143	18
DBO170	17.0	93	143	18
DBO175	17.5	93	143	18
DBO180	18.0	93	143	18
DBO185	18.5	101	153	20
DBO190	19.0	101	153	20
DBO195	19.5	101	153	20
DBO200	20.0	101	153	20

unit : mm



DCO

鎢鋼鑽頭(內冷孔)
CARBIDE DRILLS W/ INTERNAL COOLANT HOLE

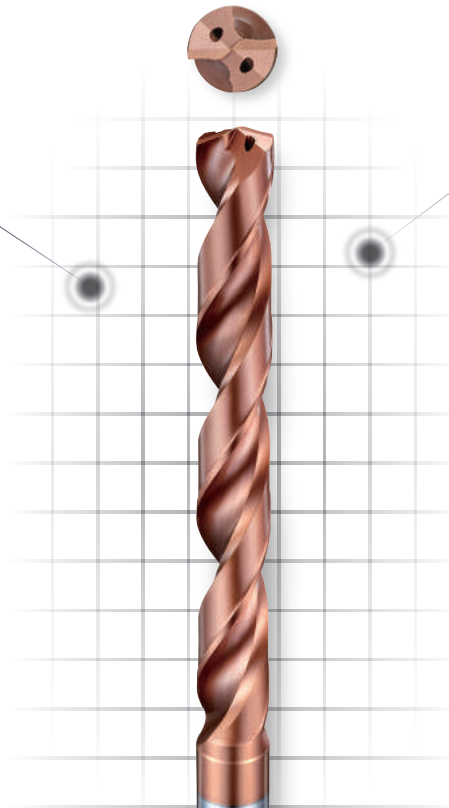
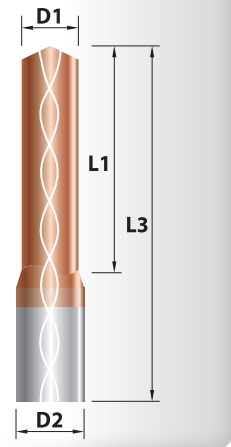

公差表 TOLERANCE unit : mm

直徑 D1	直徑公差值 D1 Tolerance	柄徑 D2	柄徑公差值 D2 Tolerance
3.0~5.9	0 -0.012	Ø6	0 -0.008
6.0~11.9	0 -0.015	Ø8	0 -0.009
12.0	0 -0.018	Ø10	0 -0.009
		Ø12	0 -0.011

產品規格 SPECIFICATIONS

型號 Type No.	D1 直徑 Diameter	L1 刃長 Flute Length	L3 全長 O.A.L.	D2 柄徑 Shank Dia.	型號 Type No.	D1 直徑 Diameter	L1 刃長 Flute Length	L3 全長 O.A.L.	D2 柄徑 Shank Dia.
DCO040	4.0	43	81	6	DCO061	6.1	76	114	8
DCO041	4.1	43	81	6	DCO062	6.2	76	114	8
DCO042	4.2	43	81	6	DCO063	6.3	76	114	8
DCO043	4.3	43	81	6	DCO064	6.4	76	114	8
DCO044	4.4	43	81	6	DCO065	6.5	76	114	8
DCO045	4.5	43	81	6	DCO066	6.6	76	114	8
DCO046	4.6	43	81	6	DCO067	6.7	76	114	8
DCO047	4.7	43	81	6	DCO068	6.8	76	114	8
DCO048	4.8	57	95	6	DCO069	6.9	76	114	8
DCO049	4.9	57	95	6	DCO070	7.0	76	114	8
DCO050	5.0	57	95	6	DCO071	7.1	76	114	8
DCO051	5.1	57	95	6	DCO072	7.2	76	114	8
DCO052	5.2	57	95	6	DCO073	7.3	76	114	8
DCO053	5.3	57	95	6	DCO074	7.4	76	114	8
DCO054	5.4	57	95	6	DCO075	7.5	76	114	8
DCO055	5.5	57	95	6	DCO076	7.6	76	114	8
DCO056	5.6	57	95	6	DCO077	7.7	76	114	8
DCO057	5.7	57	95	6	DCO078	7.8	76	114	8
DCO058	5.8	57	95	6	DCO079	7.9	76	114	8
DCO059	5.9	57	95	6	DCO080	8.0	76	114	8
DCO060	6.0	57	95	6	DCO081	8.1	95	142	10

型號 Type No.	D1 直徑 Diameter	L1 刃長 Flute Length	L3 全長 O.A.L.	D2 柄徑 Shank Dia.
DCO082	8.2	95	142	10
DCO083	8.3	95	142	10
DCO084	8.4	95	142	10
DCO085	8.5	95	142	10
DCO086	8.6	95	142	10
DCO087	8.7	95	142	10
DCO088	8.8	95	142	10
DCO089	8.9	95	142	10
DCO090	9.0	95	142	10
DCO091	9.1	95	142	10
DCO092	9.2	95	142	10
DCO093	9.3	95	142	10
DCO094	9.4	95	142	10
DCO095	9.5	95	142	10
DCO096	9.6	95	142	10
DCO097	9.7	95	142	10
DCO098	9.8	95	142	10
DCO099	9.9	95	142	10
DCO100	10.0	95	142	10
DCO101	10.1	114	162	12
DCO102	10.2	114	162	12
DCO103	10.3	114	162	12
DCO104	10.4	114	162	12
DCO105	10.5	114	162	12
DCO106	10.6	114	162	12
DCO107	10.7	114	162	12
DCO108	10.8	114	162	12
DCO109	10.9	114	162	12
DCO110	11.0	114	162	12
DCO111	11.1	114	162	12
DCO112	11.2	114	162	12
DCO113	11.3	114	162	12
DCO114	11.4	114	162	12
DCO115	11.5	114	162	12
DCO116	11.6	114	162	12
DCO117	11.7	114	162	12
DCO118	11.8	114	162	12
DCO119	11.9	114	162	12
DCO120	12.0	114	162	12

unit : mm